

MPI TS50 | 50 mm Manual Probe System

For accurate and reliable DC/CV and RF measurements

FEATURES / BENEFITS

Flexible Platform

- Designed for research, development and academic use in IC engineering, single die probing
- Ideal platform for load pull and high frequency noise measurement

Ergonomic Design

- Solid and stable platform in small footprint (300 x 300 mm) design
- Rigid platen accommodates up to 6 DC or 2 RF positioners
- Simple operation for stage and microscope positioning

Upgradability

- Available with various chuck options and wide range of accessories such as DC/RF/mmW MicroPositioners, Optics, microscopes and EMI shielded dark box to support various application requirements



SPECIFICATIONS

Chuck XY Stage (Standard)

Total travel range	100 x 75 mm (3.9 x 3.0 in)
Fine-travel range	25 x 25 mm fine micrometer control
Fine-travel resolution	< 2.0 μm (0.08 mils) @ 500 $\mu\text{m}/\text{rev}$
Planarity	< 10 μm
Theta travel (standard)	360°
Theta travel (fine)	$\pm 5.0^\circ$
Theta resolution	7.5×10^{-3} gradient
Movement control	Guided rail with instant lock mechanism

PROBE PLATEN

Specifications

Material	Steel
Dimensions	250 mm (Inside), 408 mm (Outside)
Chuck top to platen top	Min. 28 mm
Max. No of MicroPositioners	6 DC and 2 RF
Platen Z-height movement	High resolution screw for fine control
Z-height adjustment range	Max. 25 mm (1 in)
DC positioner mounting	Magnetic
RF positioner mounting	Magnetic with guide rail

NON-THERMAL CHUCKS

Standard Wafer Chuck

Diameter	56 mm
Material	Stainless steel
Chuck surface	Planar with centric engraved vacuum grooves
Vacuum grooves sections (diameter)	4, 16, 30, 44 mm
Vacuum actuation	Multizone control - All connected in meander shape, center hole in 4 mm diameter
Supported DUT sizes	Single DUT 5 x 5 mm size or wafers up to 50 mm (2 in)*
Surface planarity	$\leq \pm 5 \mu\text{m}$
Rigidity	$< 15 \mu\text{m} / 10 \text{ N @edge}$

*Single DUT testing requires higher vacuum conditions dependent upon testing application.

RF Wafer Chuck

Diameter	50 mm with 1 integrated AUX area
Material	Stainless steel with HF/OPTO surface (flat with 0.5 mm holes)
Chuck surface	Planar with 0.5 mm diameter holes in centric sections
Vacuum holes sections (diameter)	4, 16, 30, 44 mm
Vacuum holes actuation	Multizone control - vacuum hole on top, all connected at bottom in meander shape
Supported DUT sizes	Single DUT 5 x 5 mm size or wafers up to 50 mm (2 in)*
Surface planarity	$\leq \pm 5 \mu\text{m}$
Rigidity	$< 15 \mu\text{m} / 10 \text{ N @edge}$

*Single DUT testing requires higher vacuum conditions dependent upon testing application.

Auxiliary Chuck

Quantity	1 AUX chuck
Position	Integrated to rear side of main chuck
Substrate Size (W x L)	Max. 25 x 25 mm (1.0 x 1.0 in)
Material	Ceramic, RF absorbing material for accurate calibration
Surface planarity	$\leq \pm 5 \mu\text{m}$
Vacuum control	Controlled independently, separate from chucks

Electrical Specification (Coax)

Operation voltage	Standard - in accordance with EC 61010, certificates for higher voltages available upon request
Maximum voltage between chuck top and GND	500 V DC
Isolation	> 2 GΩ

FACILITY REQUIREMENTS

Power	100-240 V AC nominal; 50/60 Hz for optical accessories* only
Vacuum	-0.5 bar (for single DUT) / -0.3 bar (for wafers)
Compressed air for optional vibration isolation platform	Work pressure 0.2 ~ 0.7 MPa (2.0 ~ 7.0 bar)

* e.g. microscope illumination, CCD cameras, monitors

REGULATORY COMPLIANCE

- Certification: CE

WARRANTY

- Warranty*: 12 months
- Extended service contract: contact MPI Corporation for more information

*See MPI Corporation's Terms and Conditions of Sale for more details.

PHYSICAL DIMENSIONS

Station Platform with Bridge*

Dimensions (W x D x H)	300 x 300 x 590 mm (11.8 x 11.8 x 23.2 in)
Weight	~30 kg (66 lb.)

*Station accessories, such as different microscopes, cameras, or laser cutters, may change the total height.

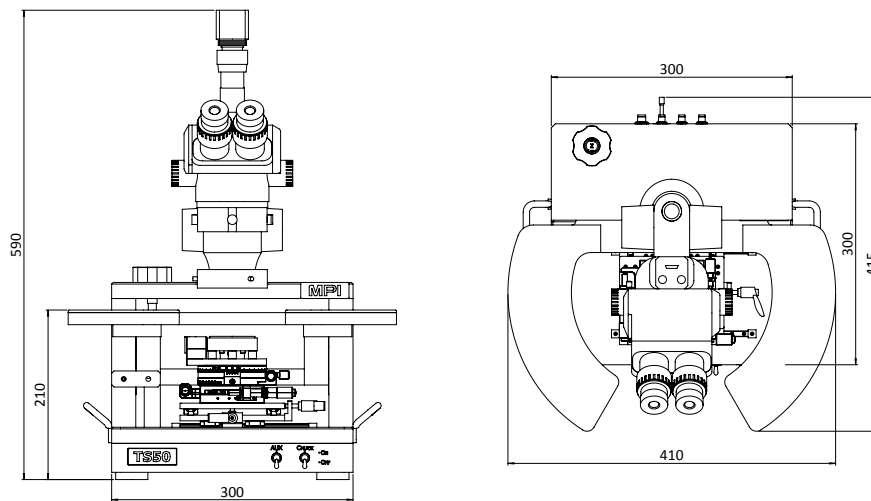

Direct contact:
 Asia region: ast-asia@mpi-corporation.com
 EMEA region: ast-europe@mpi-corporation.com
 America region: ast-americas@mpi-corporation.com

MPI global presence: for your local support, please find the right contact here:
www.mpi-corporation.com/ast/support/local-support-worldwide

© 2020 Copyright MPI Corporation. All rights reserved.

MPI Global Presence

